

TANDY®

Portable Disk Drive 2

OPERATION MANUAL

Cat. No. 26-3814



The FCC Wants You to Know

This equipment generates and uses radio frequency energy. If not installed and used properly, that is in strict accordance with the manufacturer's instructions, it may cause interference to radio and television reception.

It has been type tested and found to comply with the limits for a Class B computing device in accordance with the specifications in Subpart J of Part 15 of FCC Rules, which are designed to provide reasonable protection against such interference in a residential installation. However, there is no guarantee that interference will not occur in a particular installation.

If this equipment does cause interference to radio or television reception, which can be determined by turning the equipment off and on, the user is encouraged to try to correct the interference by one or more of the following measures:

- Reorient the receiving antenna
- Relocate the computer with respect to the receiver
- Move the computer away from the receiver
- Plug the computer into a different outlet so that computer and receiver are on different branch circuits.

Warning

This equipment has been certified to comply with the limits for a Class B computing device, pursuant to Subpart J of Part 15 of FCC Rules. Only peripherals (computer input/output devices, terminals, printers, etc.) certified to comply with the Class B limits may be attached to this computer. Operation with non-certified peripherals is likely to result in interference to radio and TV reception.

2/86

Portable Disk Drive 2 Operation Manual:
Copyright 1986 Tandy Corporation
All Rights Reserved.

Reproduction or use, without express written permission from Tandy Corporation and/or its licensor, of any portion of this manual is prohibited. While reasonable efforts have been taken in the preparation of this manual to assure its accuracy, Tandy Corporation assumes no liability resulting from any errors or omissions in this manual, or from the use of the information contained herein.

TERMS AND CONDITIONS OF SALE AND LICENSE OF TANDY COMPUTER EQUIPMENT AND SOFTWARE PURCHASED FROM RADIO SHACK COMPANY-OWNED COMPUTER CENTERS, RETAIL STORES AND RADIO SHACK FRANCHISEES OR DEALERS AT THEIR AUTHORIZED LOCATIONS

LIMITED WARRANTY

I. CUSTOMER OBLIGATIONS

- A. CUSTOMER assumes full responsibility that this computer hardware purchased (the "Equipment"), and any copies of software included with the Equipment or licensed separately (the "Software") meets the specifications, capacity, capabilities, versatility, and other requirements of CUSTOMER.
- B. CUSTOMER assumes full responsibility for the condition and effectiveness of the operating environment in which the Equipment and Software are to function, and for its installation.

II. LIMITED WARRANTIES AND CONDITIONS OF SALE

- A. For a period of ninety (90) calendar days from the date of the Radio Shack sales document received upon purchase of the Equipment, RADIO SHACK warrants to the original CUSTOMER that the Equipment and the medium upon which the Software is stored is free from manufacturing defects. **This warranty is only applicable to purchases of Tandy Equipment by the original customer from Radio Shack company-owned computer centers, retail stores, and Radio Shack franchisees and dealers at their authorized locations.** The warranty is void if the Equipment or Software has been subjected to improper or abnormal use. If a manufacturing defect is discovered during the stated warranty period, the defective Equipment must be returned to a Radio Shack Computer Center, a Radio Shack retail store, a participating Radio Shack franchisee or a participating Radio Shack dealer for repair, along with a copy of the sales document or lease agreement. The original CUSTOMER'S sole and exclusive remedy in the event of a defect is limited to the correction of the defect by repair, replacement, or refund of the purchase price, at RADIO SHACK'S election and sole expense. RADIO SHACK has no obligation to replace or repair expendable items.
- B. RADIO SHACK makes no warranty as to the design, capability, capacity, or suitability for use of the Software, except as provided in this paragraph. Software is licensed on an "AS IS" basis, without warranty. The original CUSTOMER'S exclusive remedy, in the event of a Software manufacturing defect, is its repair or replacement within thirty (30) calendar days of the date of the Radio Shack sales document received upon license of the Software. The defective Software shall be returned to a Radio Shack Computer Center, a Radio Shack retail store, a participating Radio Shack franchisee or Radio Shack dealer along with the sales document.
- C. Except as provided herein no employee, agent, franchisee, dealer or other person is authorized to give any warranties of any nature on behalf of RADIO SHACK.
- D. **EXCEPT AS PROVIDED HEREIN, RADIO SHACK MAKES NO EXPRESS WARRANTIES, AND ANY IMPLIED WARRANTY OF MERCHANTABILITY OR FITNESS FOR A PARTICULAR PURPOSE IS LIMITED IN ITS DURATION TO THE DURATION OF THE WRITTEN LIMITED WARRANTIES SET FORTH HEREIN.**
- E. Some states do not allow limitations on how long an implied warranty lasts, so the above limitation(s) may not apply to CUSTOMER.

III. LIMITATION OF LIABILITY

- A. **EXCEPT AS PROVIDED HEREIN, RADIO SHACK SHALL HAVE NO LIABILITY OR RESPONSIBILITY TO CUSTOMER OR ANY OTHER PERSON OR ENTITY WITH RESPECT TO ANY LIABILITY, LOSS OR DAMAGE CAUSED OR ALLEGED TO BE CAUSED DIRECTLY OR INDIRECTLY BY "EQUIPMENT" OR "SOFTWARE" SOLD, LEASED, LICENSED OR FURNISHED BY RADIO SHACK, INCLUDING, BUT NOT LIMITED TO, ANY INTERRUPTION OF SERVICE, LOSS OF BUSINESS OR ANTICIPATORY PROFITS OR CONSEQUENTIAL DAMAGES RESULTING FROM THE USE OR OPERATION OF THE "EQUIPMENT" OR "SOFTWARE," IN NO EVENT SHALL RADIO SHACK BE LIABLE FOR LOSS OF PROFITS, OR ANY INDIRECT, SPECIAL, OR CONSEQUENTIAL DAMAGES ARISING OUT OF ANY BREACH OF THIS WARRANTY OR IN ANY MANNER ARISING OUT OF OR CONNECTED WITH THE SALE, LEASE, LICENSE, USE OR ANTICIPATED USE OF THE "EQUIPMENT" OR "SOFTWARE."** NOTWITHSTANDING THE ABOVE LIMITATIONS AND WARRANTIES, RADIO SHACK'S LIABILITY HEREUNDER FOR DAMAGES INCURRED BY CUSTOMER OR OTHERS SHALL NOT EXCEED THE AMOUNT PAID BY CUSTOMER FOR THE PARTICULAR "EQUIPMENT" OR "SOFTWARE" INVOLVED.
- B. RADIO SHACK shall not be liable for any damages caused by delay in delivering or furnishing Equipment and/or Software.
- C. No action arising out of any claimed breach of this Warranty or transactions under this Warranty may be brought more than two (2) years after the cause of action has accrued or more than four (4) years after the date of the Radio Shack sales document for the Equipment or Software, whichever first occurs.
- D. Some states do not allow the limitation or exclusion of incidental or consequential damages, so the above limitation(s) or exclusion(s) may not apply to CUSTOMER.

IV. SOFTWARE LICENSE

RADIO SHACK grants to CUSTOMER a non-exclusive, paid-up license to use the TANDY Software on one computer, subject to the following provisions:

- A. Except as otherwise provided in this Software License, applicable copyright laws shall apply to the Software.
- B. Title to the medium on which the Software is recorded (cassette and/or diskette) or stored (ROM) is transferred to CUSTOMER, but not title to the Software.
- C. CUSTOMER may use Software on a multiterminal or network system only if either, the Software is expressly labeled to be for use on a multiterminal or network system, or one copy of this software is purchased for each node or terminal on which Software is to be used simultaneously.
- D. CUSTOMER shall not use, make, manufacture, or reproduce copies of Software except for use on one computer and as is specifically provided in this Software License. Customer is expressly prohibited from disassembling the Software.
- E. CUSTOMER is permitted to make additional copies of the Software **only** for backup or archival purposes or if additional copies are required in the operation of one computer with the Software, but only to the extent the Software allows a backup copy to be made. However, for TRSDOS Software, CUSTOMER is permitted to make a limited number of additional copies for CUSTOMER'S own use.
- F. CUSTOMER may resell or distribute unmodified copies of the Software provided CUSTOMER has purchased one copy of the Software for each one sold or distributed. The provisions of this Software License shall also be applicable to third parties receiving copies of the Software from CUSTOMER.
- G. All copyright notices shall be retained on all copies of the Software.

V. APPLICABILITY OF WARRANTY

- A. The terms and conditions of this Warranty are applicable as between RADIO SHACK and CUSTOMER to either a sale of the Equipment and/or Software License to CUSTOMER or to a transaction whereby Radio Shack sells or conveys such Equipment to a third party for lease to CUSTOMER.
- B. The limitations of liability and Warranty provisions herein shall inure to the benefit of RADIO SHACK, the author, owner and/or licensor of the Software and any manufacturer of the Equipment sold by Radio Shack.

VI. STATE LAW RIGHTS

The warranties granted herein give the **original** CUSTOMER specific legal rights, and the **original** CUSTOMER may have other rights which vary from state to state.

Contents

Introduction	1
1 General Information	3
Cable Connections	4
Battery Installation	4
Optional AC Adapter	5
Auto Power Off	5
Diskette	6
System Start-up	7
System Disk	7
File management software	8
2 File Management	11
Start-up	11
Configuration of File Manager	12
Disk Bank Feature	13
Commands	14
Files	14
Load	15
Save	17
Bank	18
Kill	19
Name	20
Format	21
Menu	21
3 Error Messages	23
4 Utilities	25
BACKUP.BA	25
FREMEM. BA	28

5	26-3808 Portable Disk Drive Diskette	29
	Appendices	31
A	Specifications	33
B	Schematic Diagram	35

Introduction

The Portable Disk Drive 2 interfaces to the Tandy 102, Tandy 200 or Radio Shack Model 100 portable computer through the RS-232C port by cable. Its compactness and light weight allow you to carry it along with your portable computer.

The Disk Drive 2 can even be powered by batteries for maximum portability. Or, you can use the optional AC adapter to operate the drive from any standard electrical outlet when it will be used for an extended period of time. The power automatically shuts off after 30 minutes if the drive does not receive input from the computer.

Using the Disk Drive 2 to store your files on diskettes will give you unlimited data storage space. Although tiny in size, the 3½" diskette can store up to 200,000 bytes of data in 2 banks.

With the file management program of the utility diskette, which is provided with the drive, files can be read and loaded from diskettes made on the 26-3808 portable disk drive. In addition to the file management program (called FLOPPY), the utility diskette also contains a diskette backup program (BACKUP.BA) and a program (FREMEM.BA) for removing the file manager from computer memory.

Now you can utilize your portable computer to its greatest potential without worrying about a shortage of memory space.

General Information 1

Open the package and take out the Portable Disk Drive 2. Do not throw away the packing material or the box. These may be useful if you ever need to transport the Portable Disk Drive 2.

The Portable Disk Drive 2 package includes:

- Portable Disk Drive 2
- Utility Diskette
- Connection Cable for Portable Computer

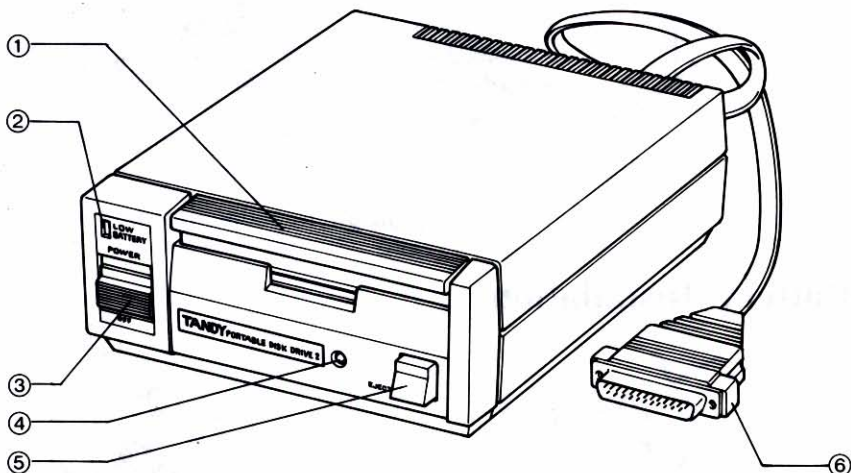

Figure 1

- | | |
|------------------------------------|---|
| ① Disk In/Out Bar | Press this bar to lock the disk drive into operating position, after you insert the diskette. |
| ② LOW BATTERY Indicator ... | This indicator lights when the batteries are weak. |
| ③ POWER Switch | Slide up this switch to turn on the power. Slide down to turn off the power. |
| ④ Access Indicator | This indicator lights when the drive is accessing the diskette. |
| ⑤ EJECT Button | Press this button to release the disk in/out bar and remove the diskette. |
| ⑥ Cable | Connects the Disk Drive to your computer. |

Cable Connections

Connect the computer and the disk drive with the connection cable as shown in Figure 2. The larger connector plugs into the RS-232C port on the rear panel of the computer. The smaller connector plugs into the RS-232C port on the rear panel of the disk drive. Both plugs are asymmetrical. If a plug cannot be inserted easily, don't force it. Just turn the plug over and try again. Be sure that the cable connections are secure. Loose connections will cause problems because data is transferred through this cable.

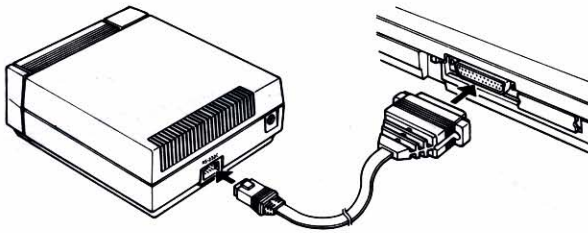

Figure 2

Battery Installation

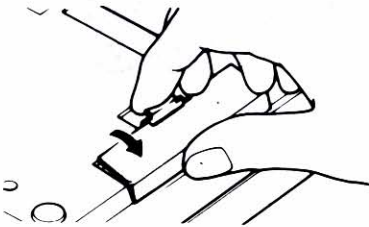

Figure 3

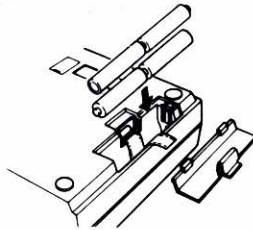

Figure 4

1. Press the tab on the bottom panel of the disk drive as illustrated in Figure 3. Remove the battery compartment cover.
2. Insert 4 AA batteries observing correct polarity, as shown in Figure 4.

Be sure to place the ribbon pull strip beneath the batteries when you install new ones. This will facilitate the removal of the batteries when they are exhausted.

3. Replace the battery compartment cover.

With 4 new alkaline batteries, the disk drive can operate continuously for up to 1.5 hours. When the low battery indicator lights, you should still have approximately 30 minutes of continuous operating time left. No operation will occur if the batteries are too low. In fact, the low battery indicator will not even light.

Notes:

1. When the batteries are weak, the low battery indicator will light. When this happens, replace all 4 batteries with new ones. We recommend our alkaline batteries, Radio Shack Cat. No. 23-552.
2. Turn off the power switch when the unit is not being used. If the unit will not be used for a long time, or if the AC adapter will be used for an extended period of time, remove the batteries to avoid damaging fluid leakage.
(Be aware that even leak-proof type batteries which are guaranteed may sometimes leak.)

Optional AC Adapter

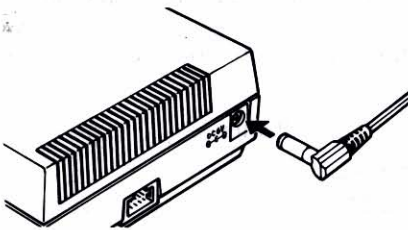

Figure 5

Connect the AC adapter (26-3804) to the DC 6V jack, and then plug the adapter into a wall outlet. The batteries will be automatically disconnected from the power supply circuit when the AC adapter is connected.

Use only the 26-3804 AC adapter. If the unit will not be used for a long period of time, disconnect the AC adapter from both the wall outlet and

this unit's jack. Do not connect and disconnect the AC adapter while the diskette is inserted the unit.

Auto Power Off

The disk drive has an auto power-off function. When no input is received from the computer after 30 minutes, the drive is automatically powered off. Even though the drive is powered off automatically, you should turn off the power switch when the drive is not being used.

Diskette

The Disk Drive 2 uses the single sided, 3 1/2" microfloppy diskette (Cat. No. 26-415 or 26-416).

Always handle your diskettes carefully. Take the same precautions you would use with your music cassettes and high-fidelity phonograph records. A small indentation, dust particle or scratch can render all or part of a diskette unreadable — permanently!

1. Always remove a diskette from the drive before turning the system on or off.

Caution: Do not eject a diskette when the access indicator is on.

2. Keep diskettes away from magnetic fields (transformers, AC motors, TVs, radios, etc.). Strong magnetic fields will erase data stored on a diskette.
3. Handle a diskette with the shutter closed. (Refer to Figure 6 below.) Do not touch any of the exposed surfaces. Do not try to wipe or clean the diskette surface; it scratches very easily.
4. Keep diskettes out of direct sunlight and away from heat.
5. Avoid contaminating diskettes with cigarette ashes, dust or other particles.
6. In extremely dusty environments, you may need to provide filtered air to the room where you use your computer.

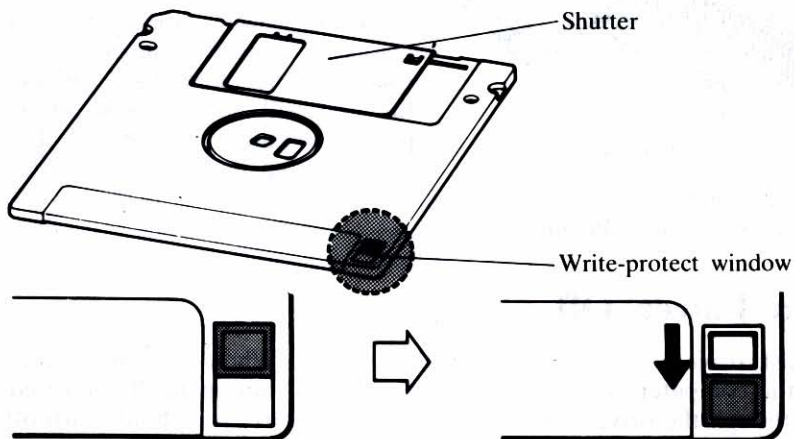

When the write-protect tab is positioned so that the window is closed, data can be written to the diskette.

When the tab is positioned so that the window is open, data is write-protected.

Figure 6

System Start-up

Be sure that the cable connections are secure and that the batteries are installed or the AC adapter is connected according to the instructions provided in this manual. If you are ready, start up the disk drive by following the procedure below.

Note: The Utility Diskette supplied with the disk drive cannot be used with any portable computer operating in conjunction with the Disk/Video Interface (26-3806)/Portable Disk Drive (26-3808).

System Disk

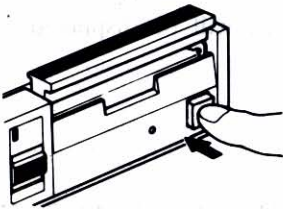

Figure 7

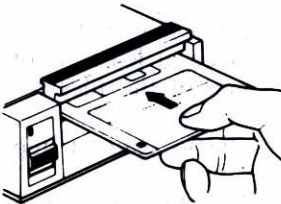

Figure 8

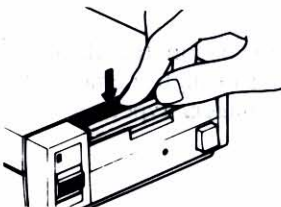

Figure 9

1. Power up your disk drive and portable computer.
2. Push the eject button. (Figure 7)
3. Remove the Head Vibration Protector and insert the utility diskette (that was provided) with the label side up, as shown in Figure 8.
Note: Use only a 3.5-inch micro-floppy diskette. If you insert the diskette with the wrong side up, damage to the diskette will occur.
4. Push down on the disk in/out bar until it snaps into place. (Figure 9)

To remove the diskette from the unit, push the eject button. If the diskette does not pop out the first time, just press the eject button again.

When the access indicator is on, do not remove the diskette from the unit.

General Information

File Management Software

1. Turn on the computer and turn OFF the disk drive.
Write-protect your utility diskette (refer to Figure 6) and insert it in the drive.
2. You will automatically enter the main menu of the computer. With the cursor over the word BASIC, press .
3. Type in the following program (Use all capital letters.):

```
10 RUN"DOM:98NIENN"   
12 SAVE"IPL" 
```

4. Type RUN .
5. Now turn on the disk drive. The following message will be displayed:

```
----INITIAL PROGRAM LOADER II----  
      WAIT A MINUTE!  
now loading file-manager
```

If this message does not appear on the display, you may have made a mistake in the operation. Press . When the Ok prompt appears, repeat the procedure from step 1.

If "?OM Error" appears on the screen, your computer does not have enough free memory to run the IPL program. (You need at least 5K of free RAM.) To resolve this problem, just delete some of the files for space and try again.

If the low battery indicator on the disk drive flickers, begin again at step 1.

After the IPL operation, the terminal settings for TELCOM will need to be changed back to your normal settings. Refer to your computer owner's manual for information on changing these settings.

Note: When the message "System exists" appears on the display, IPL cannot be run because of another program residing in high memory. If you want to erase the old program and load File Manager, type:

```
CLEAR 256,MAXRAM 
```

and try the IPL operation again from step 1.

6. After about 20 seconds, the menu will return automatically to the display. You will find "FLOPPY" in the menu.

Note: "FLOPPY" is the file name of the file management program. If you do not find "FLOPPY" in the main menu, the program was not successfully loaded. Chances are that there was not enough free memory. (You need at least 5K of free RAM available.) Delete some of the files and try again, beginning from step 1.

7. If you should have any problems with your system locking up while loading "FLOPPY", press **SHIFT** **BREAK** to free the system and press **F8** to return to the main menu. Eject the diskette and turn the disk drive's power switch to OFF, then begin again from step 1. Be sure your diskette is write-protected.

File Management 2

The Portable Disk Drive 2 performs the following file management functions shown in Table 1:

Table 1. Commands

Command	Key	Function
Files	F1	Displays the file names of all the DO , BA and CO files on the disk.
Load	F2	Loads the DO , BA or CO file on the disk to the portable computer.
Save	F3	Saves the DO , BA or CO file in the RAM of the computer to the disk.
Bank	F4	Toggles the default bank number.
Kill	F5	Erases the DO , BA or CO file on the disk.
Name	F6	Changes the file name on the disk.
Format	F7	Formats the disk.
Menu	F8	Exits and returns to the main menu of the computer.

Start-up

1. Turn on the computer and the disk drive. Insert a diskette.
2. In the main menu of the computer, move the cursor to FLOPPY and press **ENTER**.
3. The following command menu appears:

```
Sep 30,1986 Sat 00:00:00          Bank x
```

```
Disk File Manager   Ver.02.00.00
```

```
RAM: xxxxx Bytes free
```

```
File Load Save Bank Name Kill Fmt  Menu
```

00:00:00 represents the time (hour:minute:second) which is shown on the main menu. xxxxx Bytes free indicates the amount of free RAM available in your computer.

4. By pressing any of the keys **[F1]-[F8]**, you can select and execute the commands of the file management program.

Configuration of File Manager

The memory map of the computer while FLOPPY is installed is shown in Figure 10.

High address

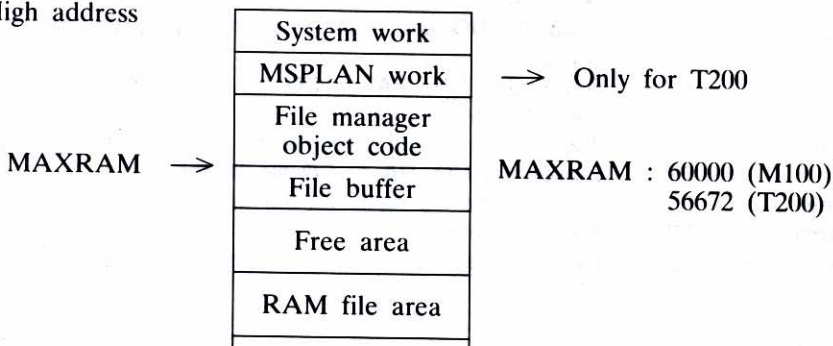

Figure 10

FLOPPY itself is not the main body of the file manager, but the initial check and boot module. Though it has no extension, its construction is a .CD file. The object of the file manager is invisible. Once you install FLOPPY by running the IPL program, a part of the high memory is occupied and the MAXRAM value is decreased to protect FLOPPY. Some application programs that use the high memory will not work or will violate FLOPPY. If you want to erase FLOPPY, use the utility program FREMEM.BA stored on the system diskette. See **Utilities**.

Disk Bank Feature

The file manager of the Portable Disk Drive 2 supports a disk bank feature. The storage space of a diskette is divided into two portions called "disk banks." Each bank can contain a maximum of 40 file entries and 200K bytes of data, but total storage capacity of the two banks cannot exceed 200K bytes.

The disk bank is specified by the number 0 or 1. The file manager holds the default bank number. When you omit the bank number in specifying the disk name, the default bank is assumed. The default bank number is set to 0 initially and can be changed with the BANK command (F4) of the file manager. Of course, you can specify the bank. (Refer to the Load, Save and Bank commands in the next section.)

The disk bank feature may seem as if there are two disks, although you actually have one diskette.

This will be useful for classifying a document, program versions, etc.

Commands

Files

1. When the command menu appears on the display, press **F1**.
2. All file names and their file size (in bytes) will be displayed.

Example:

```
File      Disk bank :0
AMERIC.DD 2300   BCC   .BA  699
CANADA.DD 5829   F5HC  .BA   59
TTCFG .BA  49    WGH50 .CD  2119
```

File names are displayed with up to 12 or 28 names on 1 screen, depending on the computer you are using. If there are more than 12 or 28 names, press any key to display the rest of the file names on the next screen. There can be a maximum of 40 files on each disk bank and 80 files on diskette.

3. At the bottom of the last screen of file names on the disk, you will see the amount of free space available on the diskette.

Example:

```
15600 Bytes free
Hit any Key.
```

4. Press any key and the command menu will return to the display.

To check the contents of another bank, press **F4** at the command menu and press **F1**.

Load

1. When the command menu appears on the display, press **F2**.
2. The computer will ask you which file you want to load from the disk.

```
Load      Disk bank :0
AAA      .BA  358    DOC    .DO  1280
FLOPPY.CO 12345  TANDY .DO  3312
```

Select file:

If you want to see the next page of the file menu, press **ENTER**.

Select file: **ENTER**

If you want to see the file name of another bank, type:

Select file:1: **ENTER**

3. Type in the file name with the appropriate extension.

Select file:TANDY.DO **ENTER**

If you want to load the file in another bank, type:

Select file:0:BCC.CO **ENTER**

4. The computer will ask you for the file name in RAM to which this disk file is to be loaded.

File name in RAM:

If you want to assign the same file name as on disk, just press **ENTER**. The computer will name the file in RAM the same as on disk.

The extension (file type, **.DO**, **.BA**, **.CO**) of the file name in RAM will automatically be the same as the disk file name, even if you don't key it in. If you key in a different extension, the computer will disregard it and make the proper extension.

File Management

5. If the file name designated in step 4 already exists in RAM, the computer will send the message:

Already exists. Are you sure? (Y/N)

If you want to overwrite the existing file in RAM and load the file from disk, press **Y** **ENTER**. If you don't want to overwrite the existing file in RAM, press **N** **ENTER**. Then the command menu will return to the display.

If the free RAM area on the computer is not sufficient to load the file, "Lack of Space" will be displayed. This means you will need to delete some of the files.

6. After loading a file, you will see the following message:

Ok

Hit any Key.

7. Press any key to return the command menu to the display.

Save

1. When the command menu appears on the display, press .
2. The computer will ask you which file you want to save from RAM:

```
Save      Disk bank :0
AAA.DO    USDOLL.DO  JAPAN.DO   BBB.BA
TKCHHC.BA CCC.CO    FWFF07.CO CH6309.CO
```

Select file:

3. After you type in the file name with the appropriate extension (for example, AAA.DO), the computer will ask you for the file name on the disk to which the RAM file is to be saved.

```
Save as      :
```

If you want to assign the same file name as in RAM, just press . The computer will name the file on disk the same as in RAM.

Note: The extension (file type) of the file name on disk will automatically be the same as that of the RAM file, even if you do not key it in. If you key in a different extension, the computer will disregard it and make the proper extension.

If you want to save the file in another bank, type:

```
Save as      :1:JAPAN.DO
```

4. If the file name designated in step 3 already exists on disk, the computer will ask you:

```
Already exists. Are you sure? (Y/N)
```

If you want to overwrite the existing file on disk and save the file from RAM, press . If you don't want to overwrite the existing file on disk, press . Then the command menu will return to the display.

When the free area on the disk is not sufficient to save the file, "Lack of Space" will be displayed. This means you will need to delete some files or use another disk with more free area.

File Management

5. After saving a file, you will see the message:

```
OK  
Hit any Key.
```

6. Press any key to return the command menu to the display.
If you attempt to save a file to a diskette, that is only partially formatted, the file may not be properly saved even though the "OK" prompt appears. After you save a file on a newly-formatted disk, press **F1** (the Files command) to be sure the file was properly saved. If it was not, begin again by re-formatting the disk.

Bank

1. Press **F4** and the default bank is toggled automatically.

The default bank number is displayed in the upper right corner of the FLOPPY menu:

```
Bank: x
```

x indicates the default bank number 0 or 1. It toggles between 0 and 1 each time you press **F4**.

Kill

1. When the command menu appears on the display, press **[F5]**.
The computer will ask you for the name you want to erase.

```
Kill      Disk bank :0
BCCBO .CO 5489   F5HC46.CO 3210
TANDY .DO 5689   USA .DO 12345
```

Select file:

2. After you type in the file name (for example, USA.DO **[ENTER]**).
The computer will make sure you want to erase the file.

Are you sure? (Y/N)

If you key in **[Y] [ENTER]**, the file will be erased and you will see the following message:

```
OK
Hit any Key.
```

The display will return to the command menu.

If you do not want to erase this file, press **[N] [ENTER]**. The display will return to the command menu.

File Management

Name

1. When the command menu appears on the display, press **[F6]**.
2. The computer will ask you which file you want to rename.

```
Name      Disk bank :0
AAA       .DO  12345  F5H4  .CO  3450
JAPAN    .DO  3657   TANDY .DO  568
```

Select file:

3. After you key in the file name (for example, TANDY.DO **[ENTER]**), the computer will ask you for the new file name.

Change to:

4. Key in the new file name (for example, RADIOS.DO **[ENTER]**). If a file with the same name as the one you just entered already exists on disk, the computer will let you know.

```
File already Exists
Hit any Key.
```

Press any key and the display will return to the command menu.

Note: The extension (file type) of the file name in the new name will be the same as in the old one, even if you do not key it in. If you key in a different extension, the computer will disregard it and make the proper extension.

5. After renaming, you will see the following message:

```
Ok
Hit any Key.
```

The display will return to the command menu.

Do not press **[SHIFT]** **[BREAK]** to stop the renaming process.

Format

1. When the command menu appears on the display, press **F7**.
2. The computer will make sure you want to format the disk.

Format. Are you sure? (Y/N)

If you don't want to format the disk, press **N** **ENTER**. The display will return to the command menu.

If you do want to format, press **Y** **ENTER** after you insert the disk. If the disk contains data, the computer will ask you:

Diskette Contains Data.
Continue? (Y/N)

If you want to retain the data and stop the formatting procedure, respond by pressing **N** **ENTER**. The display will return to the command menu. If you want to continue, press **Y** **ENTER**. While the computer is formatting the disk, the display sends the message "Formatting...". It will take about 100 seconds to format. After formatting, you will see the following message:

Ok
Hit any Key.

Press any key and the display will return to the command menu.

When you interrupt the formatting process by pressing **SHIFT** **BREAK**, the disk drive will continue to access the disk. If this happens, the disk may not be completely formatted.

Menu

When you want to return to the main menu of the computer, press **F8**. The display returns to the main menu.

Error Messages 3

When errors occur in the system, the display will show an error message. These error messages along with the possible causes are listed below. If you should get an error message, press any key to return to the command menu.

Drive not Ready

1. The drive is not turned on or the batteries installed in the drive are exhausted.
2. The cable is not connected.
3. The drive has mechanical trouble.
4. The drive is formatting a disk.
5. The drive has automatically powered off.

Communication Error

1. During communication with the computer, the power to the drive is cut off.
2. During communication with the computer, the cable is disconnected from the computer and/or from the drive.
3. During communication with the computer, a checksum error occurs.

Abort

1. Pressing **[SHIFT]** **[BREAK]** stops the command being executed.
2. Abort occurs if you change the diskette while executing the Name command.

File not Found

The file designated does not exist in the RAM of the computer or on disk.

File already Exists

The file designated already exists in the RAM of the computer or on disk.

Error Messages

Lack of Space

1. The free area is insufficient for creating a new file in the RAM of the computer or on disk.
2. The working area in RAM is insufficient for executing NAME or BACKUP.

Write Protected

When the disk is write-protected, the portable disk drive cannot write data to it.

Hard Trouble

Undefined error.

Disk I/O Error

1. The data on the disk is destroyed.
2. The disk is not formatted.
3. The disk is physically damaged.
4. The drive has a mechanical problem.

Disk Out

The disk is not inserted in the disk drive.

File Empty

An attempt is made to SAVE a file which has no data.

Invalid File Type

An attempt is made to LOAD a different type of the file other than **.BA**, **.DO**, or **.CO**.

Low Battery

When the batteries are weak, this message will be displayed beneath the "Bank x" indicator in FLOPPY's main menu. In this case, change all 4 batteries to new ones.

No bank

You tried to access the file of the 26-3808 diskette on Bank 1.

Unformatted

You tried to access an unformatted diskette.

The utility diskette contains 3 programs: FLOPY2.SYS , BACKUP.BA and FREMEM.BA .

FLOPY2.SYS is the file manager code and cannot be loaded by the load function of the file manager. It is loaded and installed only by the IPL operation. BACKUP.BA and FREMEM.BA are BASIC programs which are used for duplicating a system disk or removing FLOPPY from RAM.

BACKUP.BA

BACKUP.BA is used for disk duplication. This program not only supports a data disk but also the utility disk backup. We recommend that you first make another utility diskette for protection against accidental damage. FLOPPY must be installed in your computer. BACKUP.BA does not work without FLOPPY .

First, you need to load BACKUP.BA into the RAM of your computer by using FLOPPY. (Refer to the previous section on **load operation**.) Now, locate BACKUP.BA on the main menu and move the cursor over it. Press .

1) Opening Title

```
BACKUP UTILITY Ver.01.02
```

```
Insert BLANK disk, then hit any key
```

Pressing any key causes BACKUP to examine the disk and warn you if the disk contains data.

```
Diskette Contains Data.  
Continue? (Y/N)
```

If you want to retain the data and stop the backup procedure, press . Pressing causes BACKUP to begin disk formatting and continues the backup procedure. Formatting takes about 110 seconds.

2) Reading data from the SOURCE disk

Prepare the original disk (called the SOURCE disk) and the BLANK disk. Be sure to write protect the SOURCE disk. The BLANK disk must not be write-protected.

The following screen appears:

```
Keep SOURCE disk write-protected

Current working Sector No. = ###

Insert SOURCE disk, then hit any key
```

Insert the SOURCE disk and press any key. The disk drive reads as much data from the SOURCE disk as it can store in the RAM of the computer. The sector being read is displayed at ### area.

3) Writing Data to a BLANK Disk

After step 2), the following message is displayed:

```
Insert BLANK disk, then hit any key
```

Remove the SOURCE disk from the drive and insert the BLANK disk. Then press any key. The disk drive writes the data stored in RAM to the BLANK disk. And the sector being written to is displayed.

Repeat the step 2) and step 3) operations until all information is copied.

4) Completing the Backup

The backup is complete when the working sector count reaches #0.

5) Error Messages for Backup

Message	Description
No system	FLOPPY is not installed in the computer.
Lack of Space	BACKUP needs about a minimum of 2K bytes free RAM space in the computer for the data buffer. When this message is displayed, you will need to delete some of the RAM files to free the space.
Write protected	You attempted to format a write-protected disk.
Disk is not correct	You inserted a SOURCE disk instead of the BLANK disk or vice versa.
Disk Out	Disk is not correctly inserted.
Drive not ready	The drive is not turned on or the batteries are not installed in the drive. The cable is not connected.
Disk I/O Error	This error occurs during reading or writing to the disk. When this error occurs repeatedly, there is a mechanical problem in the drive.
Hard trouble	Re-try the backup operation. If this error occurs repeatedly, there is a mechanical problem in the drive.

Notes:

- As mentioned previously, BACKUP uses free RAM for a sector buffer. The number of sectors copied at one time depends on the amount of free RAM. If a lot of free space is available in RAM, fewer disk changes will be required.
- To abort the backup procedure, press when the display prompts "hit any key". Pressing also aborts the backup, but the original HIMEM of the computer will not be restored. If you exit BACKUP by pressing , execute the following BASIC command to free the RAM space:

```
CLEAR 256,MAXRAM 
```

FREMEM.BA

FREMEM.BA is used for removing the file manager (FLOPPY) from memory. Once FLOPPY is installed in the computer, MAXRAM is changed. Even if you erase FLOPPY with the BASIC KILL command, MAXRAM remains changed. FREMEM.BA erases FLOPPY and recovers MAXRAM.

To use FREMEM.BA, load it from the utility diskette into the RAM of the computer by using FLOPPY. Move the cursor over FREMEM.BA and press . You will see following message:

```
Kill the 'FLOPPY' and free the space  
Are you sure (Y/N) ?
```

If you want to remove FLOPPY, press . Pressing returns the main menu without erasing FLOPPY.

26-3808 Portable Disk Drive Diskette **5**

The diskette prepared for the 26-3808 portable disk drive can be used with Portable Disk Drive 2 with the following restrictions:

1. The files on the 26-3808 diskette are considered to be on bank 0. If you try to list the files on bank 1, the display shows "No bank."
2. You can use the File and Load commands only. When the Save, Kill or Name command is issued, your portable computer will display "Write Protected."

To change the 26-3808 diskette to a Portable Disk Drive 2 diskette, follow this procedure:

1. Insert the 26-3808 diskette in the Drive.
2. At the main menu, highlight FLOPPY and press **ENTER**.
3. Press **F2** and load the file into your computer.
4. Repeat step 3 until all the files you want to retain are loaded in RAM.
5. Press **F7** to format the diskette to the Disk Drive 2 system.
6. When formatting is completed, press **F3** and save the file in RAM to the diskette. Repeat this as many times as necessary.

If the size and/or number of files is too large to store in your computer RAM, you will have to save the file(s) to another Portable Disk Drive 2 diskette.

Appendices

Specifications **A**

Storage capacity (Formatted)

Per disk	202.24K bytes
Per track	2,560 bytes
Per hard sector	1,280 bytes

Disk

Number of surface	1
Number of memory blocks	
Total number of tracks	80
Total number of hard sectors	160

Recording systems

Recording method	FM
Recording density	4,064 BPI
Track density	135 TPI
Data transfer rate	125K bits/sec.

Process time

Average access time	710 ms
Track-to-track	40 ms
Settling time	20 ms
Motor start time	1 s

Rotational speed 300 rpm

Number of Indices 2

Power sources 4 AA alkaline batteries
(23-552)
or
AC adapter (26-3804)

Specifications

Power consumption

Operating	1.8 W
Waiting	0.08W

Battery life

Continuous Read/Write	Minimum 1.5 hours
Waiting only	Minimum 20 hours

Low Battery

Alarm lamp	Average voltage, 4.1V
Power down	Average voltage, 3.5V

Weight	1 lb. 14 oz., 850 grams (including 4 batteries)
--------------	--

Dimensions	5-1/4" × 6-13/32" × 2-1/8" 133 (W) x 163 (L) x 54 (H) mm
------------------	---

Media used	3.5-inch microfloppy disk, Single-sided (Cat. No. 26-415 or 26-416)
------------------	--

Interface	RS-232C
-----------------	---------

Transfer rate	Booting, 19200 bits/sec. Operating, 19200 bits/sec.
---------------------	--

Accessories	3.5" System Diskette RS-232C Connector Cable
-------------------	---

Schematic Diagram B

Main PCB

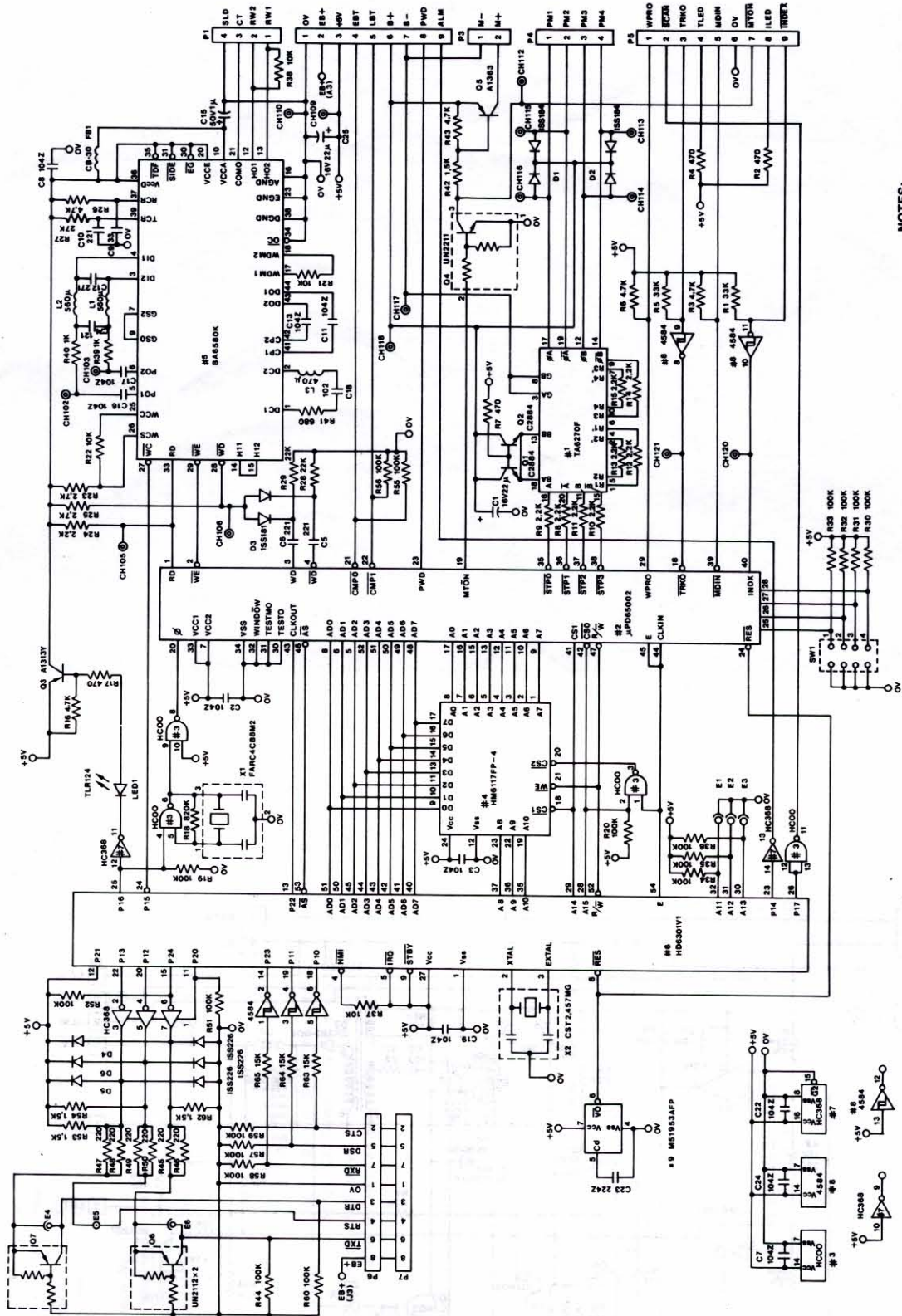

NOTES:
A) RATED POWER OF UNSPECIFIED RESISTOR: 1/8W
B) #104: TC50H000F, #105: TC4584F, #106: TC40H010F

Schematic Diagram

DC-DC Converter

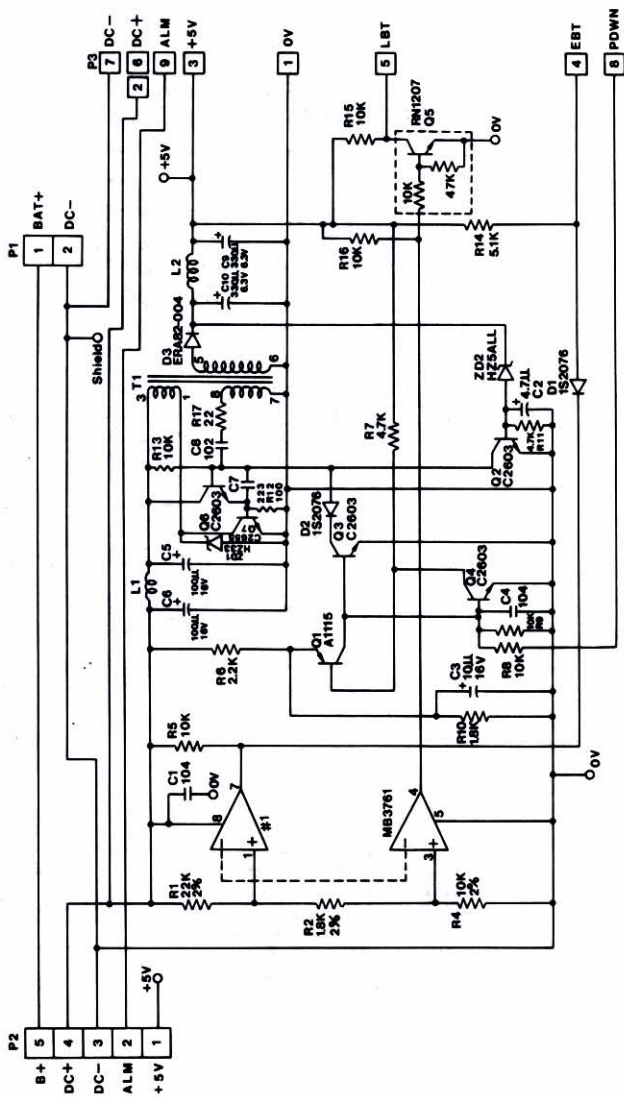

SERVICE POLICY

Radio Shack's nationwide network of service facilities provides quick, convenient, and reliable repair services for all of its computer products, in most instances. Warranty service will be performed in accordance with Radio Shack's Limited Warranty. Non-warranty service will be provided at reasonable parts and labor costs.

6/86

RADIO SHACK
A Division of Tandy Corporation
Fort Worth, Texas 76102